



SOUNDCAST



OUTCAST OWNER'S MANUAL
With iCast





The OutCast speaker uses a 24 volt Nickel Metal Hydride battery for DC operation. Please review the following safety instructions before use:

Ni-MH Batteries Safety Instructions:

- Misuse can result in the batteries short-circuiting, the insulator melting and damage to the safety valves or safety mechanisms, leading to leakage, heat generation, or rupturing. Please observe the following precautions when using batteries.
- Do not dispose in fire or expose to high temperature.
- Do not under any circumstances insert the batteries with the positive and negative poles reversed.
- If the connection with the charger does not operate correctly, do not force the battery in, but instead check the direction of the positive and negative poles.
- Do not directly connect the batteries to power outlets or car cigarette lighter ports.
- Do not connect the positive terminal and the negative terminal with metals such as wire. Also, do not store or carry the batteries with metal necklaces, etc.
- Do not disassemble or modify the battery.
- Do not directly solder the battery.
- In charging, use the only the built-in charger
- This battery is constructed to release internal gases. For this reason, do not alter the (+) terminal.
- This battery contains an alkaline liquid. If this liquid comes in contact with the eyes, this may lead to loss of sight. Without rubbing the eyes, immediately wash them with clean water and consult a doctor.
- Do not use the battery if it shows signs of leakage, a change of color or shape or any other changes in appearance.
- Do not wet the battery or place it in water or sea water. This may lead to the battery generating heat or rusting.
- Do not remove or damage the coating tube. This makes it easy for the battery to short-circuit and may cause leakage or heat generation. .
- Store the battery out of reach of small children.
- If the battery is rusted, generating heat or shows any other abnormal signs at the time of purchase, take it to the point of purchase without using it.
- When not using the battery, or not using the device for a prolonged period, remove the battery from the device and store it in a dry place between the temperatures of -20oC and +35oC. This prevents leakage, rust and decreased battery performance and service life
- Do not apply a strong force to the battery or throw it. This may cause leakage or heat generation.
- Do not place the battery in direct sunlight, in hot cars, in front of stoves or other hot places. This may lead to leakage from the battery. Also, this may deteriorate the performance and service life of the battery

Soundcast Systems
customersupport@soundcastsystems.com
www.soundcastsystems.com

IMPORTANT SAFETY INSTRUCTIONS

CAUTION: PLEASE READ THESE INSTRUCTIONS GIVEN IN THIS MANUAL AND THOSE MARKED ON THE UNIT. KEEP THESE INSTRUCTIONS FOR FUTURE REFERENCE. PLEASE HEED ALL WARNINGS AND FOLLOW ALL INSTRUCTIONS

This set has been designed and manufactured to assure personal safety. Improper use can result in electric shock or fire hazard. The safeguards incorporated in this unit will protect you if you observe the following procedures for installation, use and servicing. This unit is fully transistorized and does not contain any parts that can be repaired by the user.

AC/DC Adapter Power Supply

Use only the AC/DC adapter or power cord that was supplied by Soundcast Systems. Do not use a substitute AC/DC adapter. Using an incorrect AC/DC adapter may cause damage to the product and will void its warranty.

1. Read the instructions.
2. Heed all warnings.
3. Follow all instructions.
4. Do not use this apparatus near water. OutCast is weather resistant, not water proof.
5. Clean only with a dry cloth.
6. Do not block any ventilation openings. Install in accordance with manufacturer's instructions.
7. Do not install near any heat sources such as radiators, heat registers, stoves, or other apparatus (including amplifiers) that produce heat.
8. Do not defeat the safety purpose of the polarized or grounding-type plug. A polarized plug has two blades with one wider than the other. A grounding-type plug has two blades and a third grounding prong. The wide blade or third prong is provided for your safety. If the provided plug does not fit into your outlet, consult an electrician for replacement of the obsolete outlet. – 110 volt markets only
9. Protect the power cord from being walked on or pinched particularly at plugs, convenience receptacles, and the point where it exits from the apparatus.
10. Only use attachments/accessories specified by the manufacturer.
11. Use only with the cart, stand, tripod, bracket, or table specified by the manufacturer, or sold with the apparatus. When a cart is used, use caution when moving the cart/apparatus combination to avoid injury from tip-over.
12. Refer all servicing to qualified service personnel. Servicing is required when the apparatus has been damaged in any way, such as power supply cord or plug is damaged, liquid has been spilled or objects have fallen into the apparatus, the apparatus has been exposed to rain or moisture, does not operate normally, or has been dropped.
13. The label is adhered to the bottom of the apparatus.
14. Protective earthing terminal: The apparatus should be connected to a mains socket outlet with a protective earthing connection.
15. The mains plug is used as a disconnect device, the disconnect device shall remain readily operable.



SAFETY PRECAUTIONS



The lightning flash with arrowhead symbol, within an equilateral triangle, is intended to alert the user to the presence of un-insulated "dangerous voltage" within the product's enclosure that may be of sufficient magnitude to constitute a risk of electric shock to persons.



The exclamation point within an equilateral triangle is intended to alert the user to the presence of important operating and maintenance (servicing) instructions in the literature accompanying the appliance.

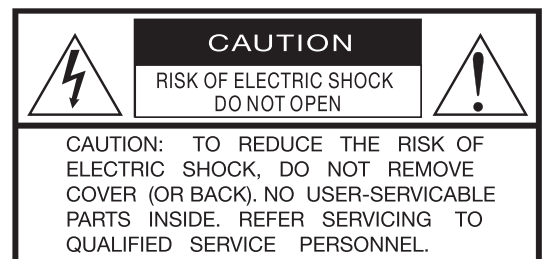

WARNING:

TO REDUCE THE RISK OF FIRE OR ELECTRIC SHOCK, DO NOT EXPOSE THIS APPLIANCE TO RAIN OR MOISTURE. DANGEROUS HIGH VOLTAGES ARE PRESENT INSIDE THE ENCLOSURE. DO NOT OPEN THE CABINET. REFER SERVICING TO QUALIFIED PERSONNEL ONLY.

CAUTION:

When replacing the direct plug-in power supply or a separable, cord-connected power supply, the replacement must be an exact duplicate, or has been recommended by the manufacturer. **TO PREVENT ELECTRIC SHOCK, MATCH THE WIDE BLADE OF PLUG TO THE WIDE SLOT, FULLY INSERT.**

OPERATING INSTRUCTIONS

Your Soundcast OutCast system consists of two items:

The Soundcast iCast transmitter and the OutCast Weather Resistant Wireless Speaker.

This manual covers the operation of each item.

iCast ICT-111/121 Transmitter

Your iCast transmitter has been designed to work properly with the following iPod® models:

iPod 3G, iPod mini, iPod 4G, iPod with color display, iPod nano, iPod with video

These models will fit directly into the dock on iCast. If your ipod came with an adapter, it will also fit in the dock. If you do not have an adaptor and would like to use one, they are available from your authorized Apple dealer.

The following items are included in this package:

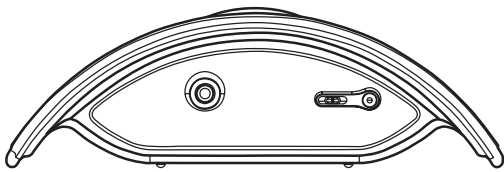

iCast Transmitter



3.5 mm Mini to RCA cable



3.5 mm Mini to Mini Cable

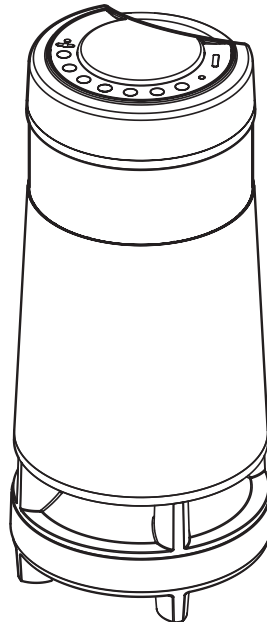

OutCast

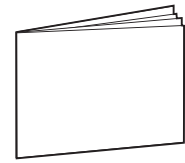

Owners Manual



Power Cord



Battery

AC/ DC Adapter

Installation:

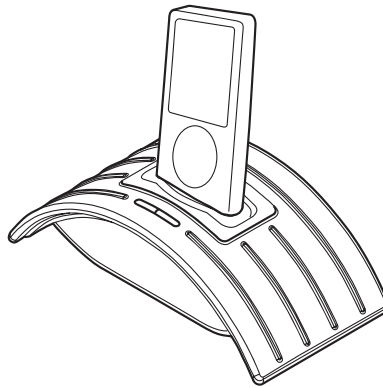

- 1.** Insert your iPod into the docking bay, locking the slot in the bottom of the iPod onto the socket located in the middle of the dock.

- 2.** Plug the AC adapter into an AC outlet wall socket and attach the power cord to your iCast Transmitter by inserting the plug into the correct socket on the back of the iCast Transmitter.

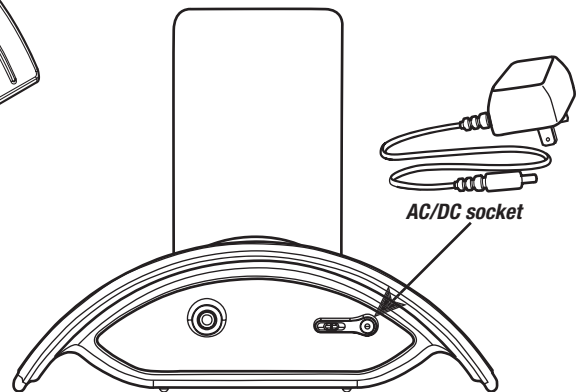

AC/DC socket

- 3.** A blue light will glow on the top of the transmitter indicating you have power.

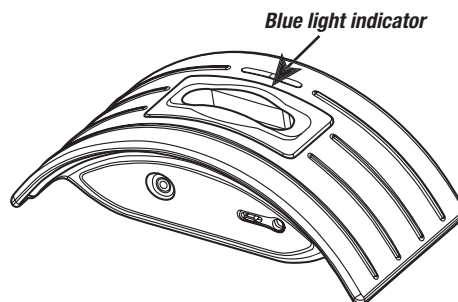

Blue light indicator

- 4.** Your iPod will charge its built-in battery while in the iCast dock. All of your iPod controls except the volume control will operate in the normal fashion while in the dock. The iPod volume is fixed when in the dock and all sound volume adjustments must be made on the OutCast unit.

If you wish to connect your iCast Transmitter to a set of headphones or to some external self-powered speakers, you may do so by inserting the plug on these devices into the headphone jack on the back of the iCast Transmitter. Please remember that the volume control on your iPod does not function while in the dock, so you can only adjust the volume if the headphones or external powered speakers permit it.

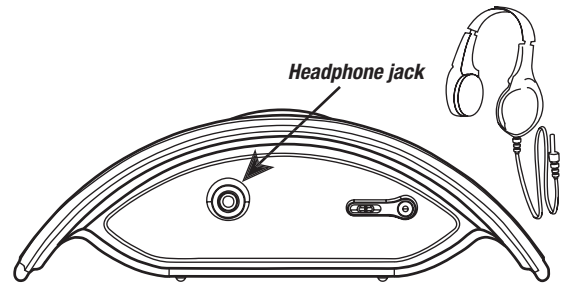

Note: iCast units do not have an internal amplifier. Any speaker systems that are attached to this product must have internal amplifiers in order to play music.

OutCast Installation:

Connect battery. Be careful to orient connector properly so it easily snaps into place.

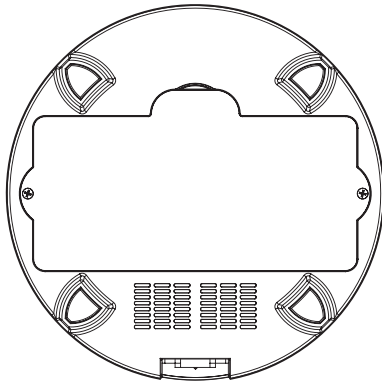

1. OutCast bottom view.
Remove battery cover screws.

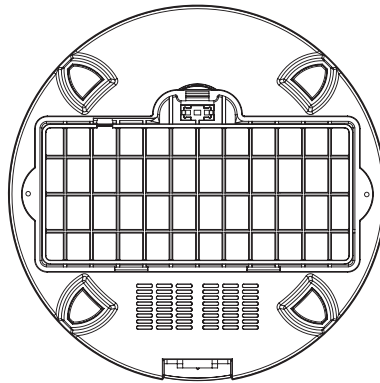

2. OutCast unit with battery cover removed.

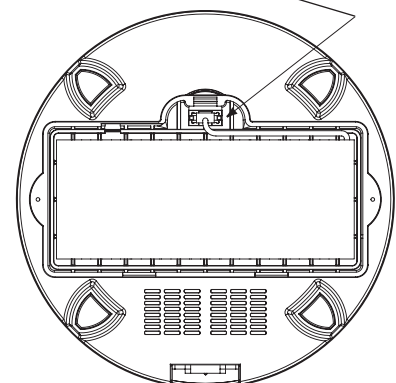

3. OutCast with battery installed carefully screw cover back in place.

Then insert the battery as shown (there is only one way the battery will fit properly due to the cable length) and replace the screws to secure the cover. There is a safety interlock in the OutCast battery cover, so the cover must be screwed into place for the OutCast to operate.

Connect the power cord to the three prong outlet on the back of OutCast and connect the plug into an AC outlet. Remove the protective plug from the AC power socket on the lower back section of OutCast and then connect the power cord to the three prong socket. Insert the power cord plug into an AC outlet. This will supply AC power to your OutCast and will also charge the battery pack. You should charge the battery pack for at least 3 hours before attempting to operate OutCast on battery power alone. Once the battery has been discharged, it will take about two to three hours to fully charge the battery if the power switch on OutCast is off. If you are charging while the unit is playing, it will take a bit longer. The battery will slowly discharge if left off for several weeks. In very hot climates this will happen more quickly. You must fully charge the battery again for best performance if your OutCast has not been used for some time. When operating your OutCast on battery power, please replace the protective safety plug back over the AC socket to prevent moisture from entering the socket.

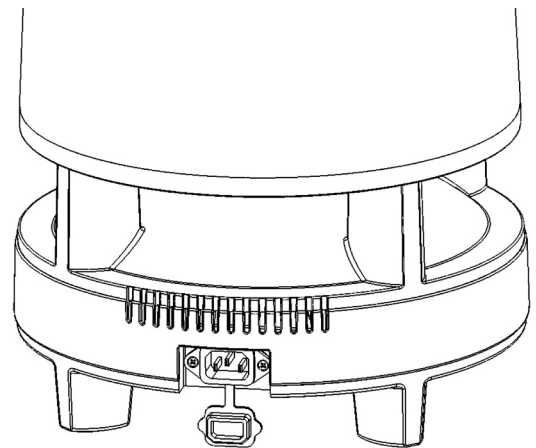

The OutCast unit will be controlled by the buttons on top. There is a green power indicator light on the right side of OutCast that indicates that the unit is turned on. When the power button on top of the unit is pressed, the light will come on. If there is a red light on the left side, it means the battery needs to be charged. The red light will flash slowly when the battery is low, stay on when battery is discharged, and it will go out completely when the battery is fully charged. When the power cord is inserted, the red light will flash rapidly for a few seconds, while the circuit self tests to check the battery charge condition. This is normal. If the battery needs charging, then the red light will stay on until the charging cycle is completed.

The button on the far right is the mood lighting on/off switch, the next two buttons are volume up and down, and the center button is power on/off. The buttons on the left are iPod control buttons – pause/play, track back and

track forward. The two LED lights are the red battery indicator on the left and the green power/blue link indicator on the right.

Operating your OutCast System

To complete your system you will need to turn on the OutCast. Once you have correctly installed your OutCast, you are ready to transmit your music. OutCast can be installed at a distance of up to 150 feet (45 meters) from your iCast Transmitter when used indoors. Outdoors, the signal may carry up to 350 feet (100 meters) depending on conditions. To maximize the distance outdoors you may wish to locate your iCast transmitter near a window facing the outdoor area you intend to use. On each Soundcast product there is a blue light that will flicker when there is no wireless link, and then glow steadily once the wireless link is established. On OutCast this light will start off green when the power switch is pressed and switch to blue after the link is in place. Once there is a wireless link you should be able to hear the music from your iPod through the OutCast system.

You can leave the iCast system hooked up 24 hours per day if you wish to do so – it is designed for continuous operation. However, if you do not intend to use the system for an extended period of time, you should disconnect the power supplies from the wall outlets to conserve energy.

Connecting Your iCast Transmitter to Your Computer or Other Music Source

Your iCast Transmitter can also transmit the audio output of other devices such as a Mac or a PC or a CD player. To use your iCast Transmitter for this function, first remove the iPod from the dock. When the iPod is removed, the headphone jack on the back of the Transmitter becomes an input jack. Two connecting cables have been included in your iCast package.

Find the audio output of your computer (usually a 3.5 mm headphone jack) and connect the included 3.5 mm mini-to-mini cable between the two devices. If your computer has stereo RCA jacks, then use the other cable. This RCA-to-mini cable can also be used to connect the output jacks of a CD player or other audio device to your iCast Transmitter.

Once you have connected the Transmitter to your computer, the operation is exactly the same as the normal installation.

However, the iPod control buttons on the OutCast will not function when there is no iPod in the dock. Those controls are only for iPod use. You must select your music and your play lists from the files stored on your computer. iCast only transmits what your computer or your CD unit is playing. **Your iCast system is strictly an audio device – it will not transmit video or any type of computer file.**

Additional Features

Your OutCast speaker can also be used with a local source, such as an MP3 player, that can be connected directly to OutCast using the mini-jack on the side of the unit, under the rubber cover. When an MP3 player or portable CD player is connected to this jack using the supplied connecting cord, then the music on that device will play instead of the music from the iCast transmitter. Once the local player has been removed, the music source will once again be the iCast. Please note that

the built in iPod controls on OutCast will not operate the MP3 player connected to the mini-jack. Please replace the rubber cover when this feature is not in use to protect the circuits from moisture.

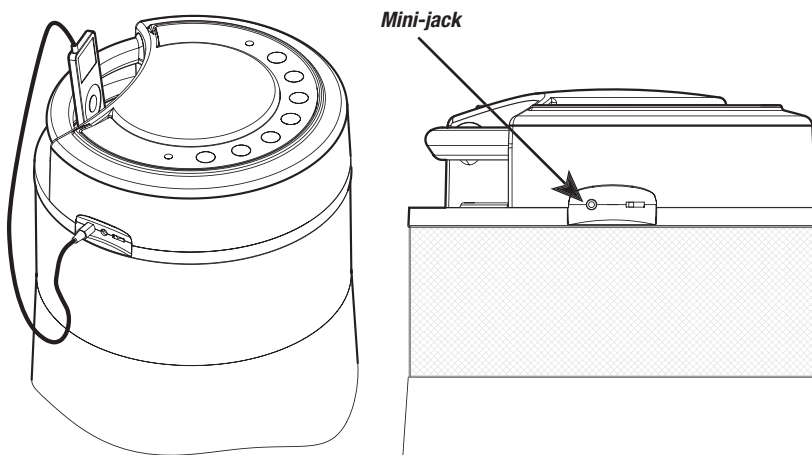
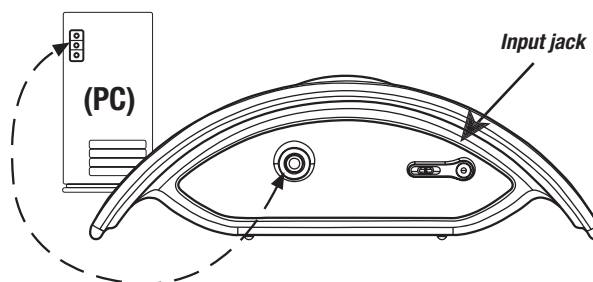
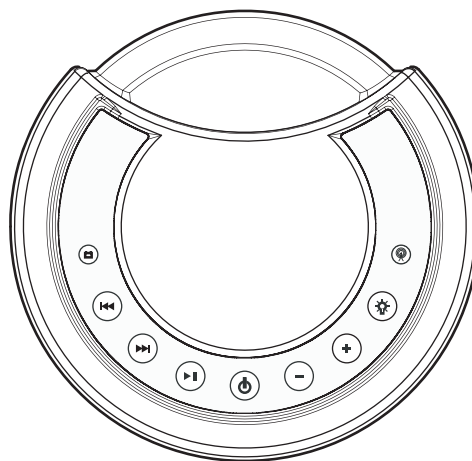

Each iCast Transmitter can also operate up to two iCast Receivers, two OutCast units or one of each. This means you can purchase iCast receivers or another OutCast from your retailer and transmit audio to two different locations in your house. All operating functions remain the same when both receivers are in operation.

It is also possible to operate two entirely different Soundcast systems in the same household if you wish. Two transmitters can operate within the same 45 meter (150 foot) radius by using the channel selector switch on the back of the unit.

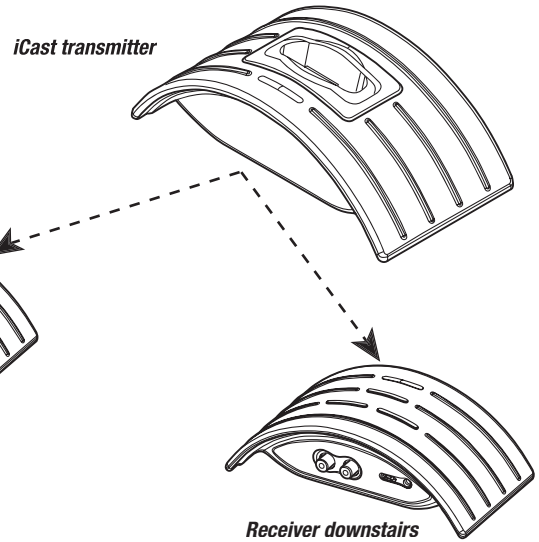

All Soundcast products come from the factory with Channel 1 selected. On the back of each Soundcast unit there is a 3 position selector switch to allow the user to select different transmission channels. On OutCast the switch is under the rubber cover on the side of the unit.

When you wish to use two Soundcast systems at the same time, leave one system on Channel 1 and move the selector switch to on the second system to Channel 2 or 3. Please remember that both the Transmitter and OutCast must set on the same Channel. When set this way, the two systems will not conflict with each other and you can use two different iPods operating two different audio systems in the same house.

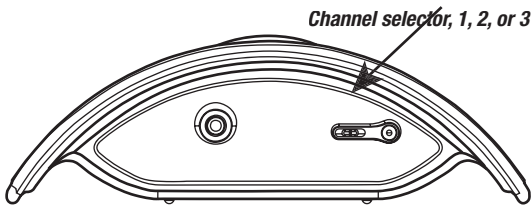
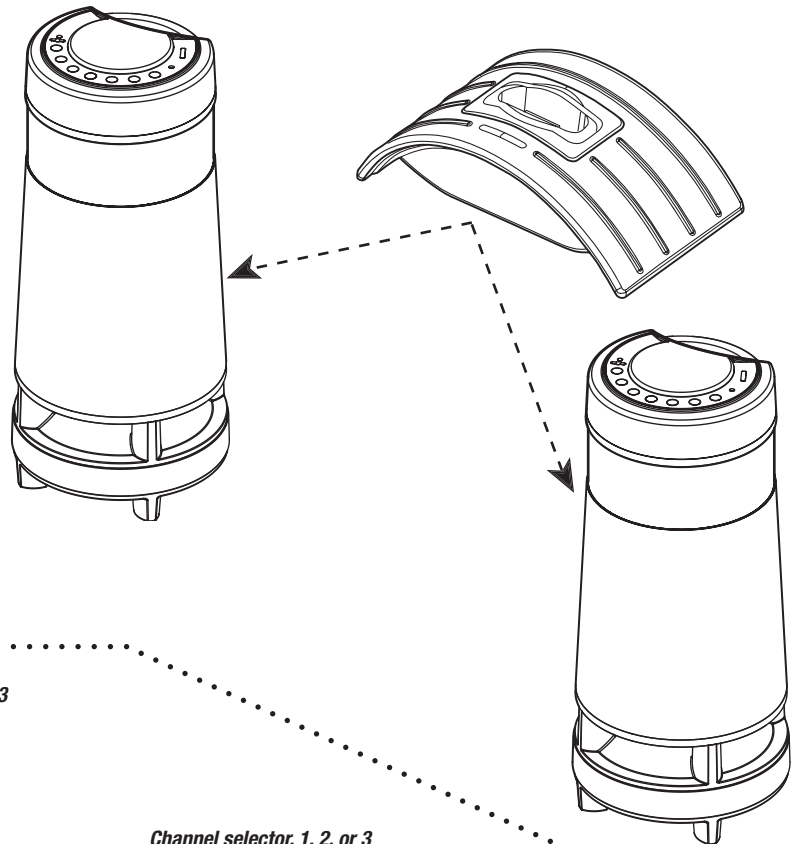

The Channel selector switch will also allow you to eliminate the signal from a neighbor's Soundcast system. If you live in an apartment building and find that you receive music from another Soundcast system, simply move the selector switches on your Soundcast Transmitter and OutCast to a different Channel and the unwanted signal will stop being received.

Should you have any additional questions concerning the installation or use of your Soundcast products, please contact Soundcast via E-mail at customersupport@soundcastsystems.com.

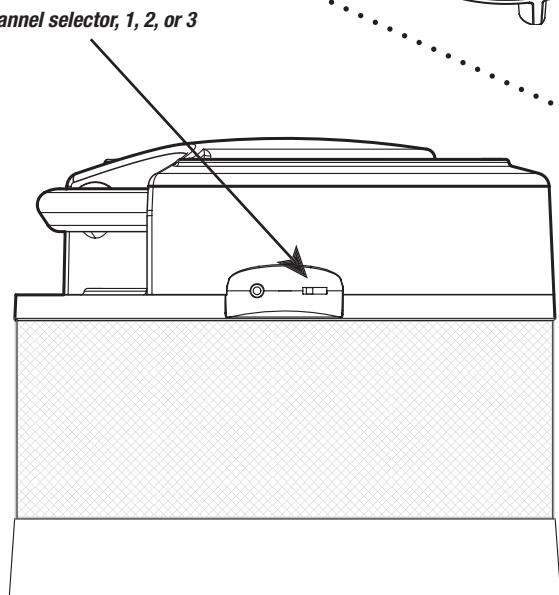

Information to User

This device complies with Part 15 of the FCC Rules. Operation is subject to the following two conditions: (1) This device may not cause harmful interference, and (2) This device must accept any interference received, including interference that may cause undesired operation.

This equipment has been tested and found to comply with the limits for Class B Digital Device, pursuant to Part 15 of the FCC Rules. These limits are designed to provide reasonable protection against harmful interference in a residential installation. This equipment generates and can radiate radio frequency energy and, if not installed and used in accordance with the instructions, may cause harmful interference to radio communications. However, there is no guarantee that interference will not occur in a particular installation. If this equipment does cause harmful interference to radio or television reception, which can be determined by turning the equipment off and on, the user is encouraged to try to correct the interference by one or more of the following measures.

- Reorient or relocate the receiver or transmitter
- Increase the separation between the equipment and receiver
- Connect the equipment into an outlet on a circuit different from that to which the receiver is connected
- Consult the dealer or an experienced radio/TV technician for help

Any changes or modifications not expressly approved by the party responsible for compliance could void the user's authority to operate the equipment.

USA & Canada Warranty

Soundcast Systems warrants to the end user ("Customer") that the hardware product will be free from defects in workmanship and materials, under normal use and service, for the following length of time from the date of purchase from Soundcast or an authorized retailer: **One (1) Year.**

Soundcast Systems' sole obligation under this express warranty shall be, at its option and expense, to repair the defective product or part, deliver to Customer an equivalent product or part to replace the defective item. All products that are replaced will become the property of Soundcast Systems. Replacement products may be new or refurbished. Soundcast Systems warrants any replaced or repaired product or part for a period of ninety (90) days from shipment, or the remainder of the initial warranty period, whichever is longer.

In no case shall Soundcast be responsible for damage to any connected audio equipment, including the iPod, resulting from misuse, abuse, neglect, improper installation or testing, unspecified application, modification or alteration of or tampering with Soundcast products.

If you need warranty service on your Soundcast Products

All warranty returns should be sent to Soundcast's Warranty Repair Service Center freight prepaid through the original selling retailer and must be accompanied by a copy of the original sales receipt. Direct returns from consumers will also be accepted, but only if accompanied by a Return Merchandise Authorization number (RMA) issued by Soundcast in advance of any shipment to the Soundcast Warranty Repair Service Center. Units returned without an RMA number to Soundcast may be subject to refusal or significant delays. Please ship the authorized return to Soundcast within 15 days of the issuance of the RMA. Repaired or replacement units will be shipped to you at Soundcast's expense. Any units with no trouble found will be returned to you freight collect. Soundcast Systems will give you the proper return address when the RMA is issued. Do not return the defective unit directly to Soundcast Systems.

For Warranty Service Please Contact:



Soundcast Systems
Warranty Claim Department
San Diego, California
US only 1-800-722-1293
customersupport@soundcastsystems.com
www.soundcastsystems.com
www.soundcast.eu

Mac and iPod are trademarks of Apple Computer, Inc., registered in the U.S. and other